

Panasonic

Color CCTV Camera Operating Instructions

Model No. **WV-CP160**

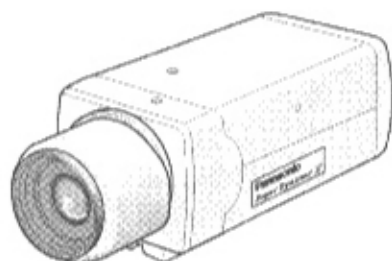

(Lens Option)

Before attempting to connect or operate this product,
please read these instructions carefully and save this manual for future use.

	CAUTION RISK OF ELECTRIC SHOCK DO NOT OPEN	
<p>CAUTION: TO REDUCE THE RISK OF ELECTRIC SHOCK, DO NOT REMOVE COVER (OR BACK). NO USER-SERVICEABLE PARTS INSIDE. REFER SER- VICING TO QUALIFIED SERVICE PERSONNEL.</p>		



SA 1965

The lightning flash with arrow-head symbol, within an equilateral triangle, is intended to alert the user to the presence of uninsulated "dangerous voltage" within the product's enclosure that may be of sufficient magnitude to constitute a risk of electric shock to persons.



SA 1966

The exclamation point within an equilateral triangle is intended to alert the user to the presence of important operating and maintenance (servicing) instructions in the literature accompanying the appliance.

For U.S.A.

NOTE: This equipment has been tested and found to comply with the limits for a Class A digital device, pursuant to Part 15 of the FCC Rules. These limits are designed to provide reasonable protection against harmful interference when the equipment is operated in a commercial environment. This equipment generates, uses, and can radiate radio frequency energy and, if not installed and used in accordance with the instruction manual, may cause harmful interference to radio communications. Operation of this equipment in a residential area is likely to cause harmful interference in which case the user will be required to correct the interference at his own expense.

FCC Caution: To assure continued compliance, (example - use only shielded interface cables when connecting to computer or peripheral devices). Any changes or modifications not expressly approved by the party responsible for compliance could void the user's authority to operate this equipment.

The serial number of this product may be found on the top of the unit.

You should note the serial number of this unit in the space provided and retain this instruction as a permanent record of your purchase to aid identification in the event of theft.

Model No. _____

Serial No. _____

WARNING:

To reduce the risk of fire or electric shock, do not expose this appliance to rain or moisture.

PREFACE

Panasonic's WV-CP160 color digital camera introduces a new level of high picture quality and high resolution through the use of a 1/3-inch interline transfer CCD image sensor having 768 horizontal pixels (picture elements), and digital signal processing LSIs. This model offers cutting-edge technology for advanced video surveillance. This VP multiplex camera can be connected with specified monitor by single coaxial cable.

PRECAUTIONS

1. Do not attempt to disassemble the camera.

To prevent electric shock, do not remove screws or covers.

There are no user serviceable parts inside. Ask a qualified service person for servicing.

2. Handle the camera with care.

Do not abuse the camera. Avoid striking, shaking, etc. The camera could be damaged by improper handling or storage.

3. Do not expose the camera to rain or moisture, or try to operate it in wet areas.

Turn the power off immediately and ask a qualified service person for servicing.

Moisture can damage the camera and also create the danger of electric shock.

4. Do not use strong or abrasive detergents when cleaning the camera body.

Use a dry cloth to clean the camera when dirty.

In case the dirt is hard to remove, use a mild detergent and wipe gently.

5. Clean the CCD faceplate with care.

Do not clean the CCD with strong or abrasive detergents. Use lens tissue or a cotton tipped applicator and ethanol.

6. Never face the camera towards the sun.

Do not aim the camera at bright objects. Whether the camera is in use or not, never aim it at the sun or other extremely bright objects. Otherwise, blooming or smear may be caused.

7. Do not operate the camera beyond the specified temperature or humidity.

Use the camera under conditions where temperature is between -10°C - $+50^{\circ}\text{C}$ (14°F - 122°F), and humidity is below 90%.

FEATURES

- The following functions are built in.
 - (1) Auto Light Control (ALC)/Electronic Light Control (ELC)
 - (2) The SUPER-D II function eliminates interference by strong background lighting which makes the camera picture dark, such as a spotlight.
Dynamic range of 46 dB.
 - (3) Auto/Manual White Balance Function
 - (4) Electronic Shutter Function
- Signal-to-noise ratio of 50 dB
- Minimum illumination of 0.8 lx (0.08 footcandle) with F 1.4 lenses.
- Minimum illumination of 0.4 lx (0.04 footcandle) with Panasonic aspherical high speed (F0.75) lenses.
- 480 lines of horizontal resolution
- High quality picture:
 - (a) 2H type picture enhancer for greater picture sharpness
 - (b) Chroma averaging circuit for better color signal-to-noise ratio
 - (c) Minimum of aliasing on fine objects
 - (d) Expanded dynamic range by use of knee circuit
 - (e) Highlight aperture correction for greater picture detail of bright objects
- Ability to shoot indoor scenes with fixed iris lens by use of Electronic Light Control (ELC) function.

MAJOR OPERATING CONTROLS AND THEIR FUNCTIONS

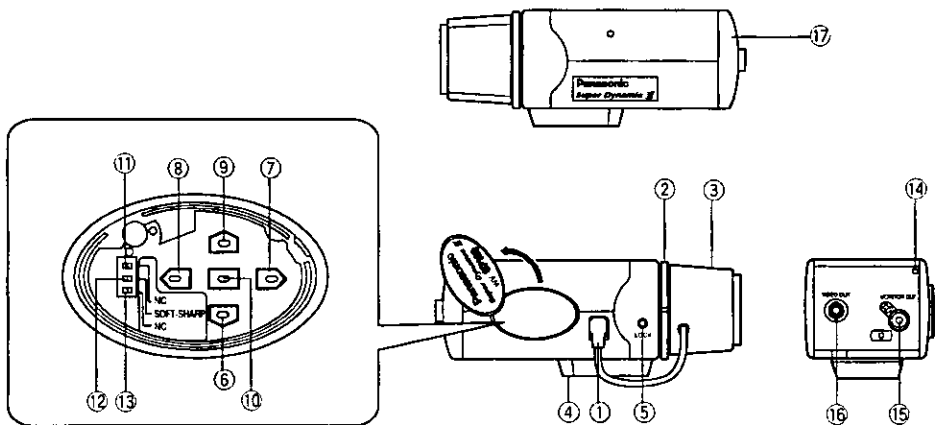

Open the panel to the upper left until it stops by rotating counterclockwise.

① Auto Iris Lens Connector

This connector is used to connect the auto iris lens. It supplies power and DC control signal to the auto iris lens.

② Flange-back Adjusting Ring

This ring is used to adjust the back focal length or picture focus by rotating it.

③ **Lens (Option)**

④ **Camera Mounting Screw Hole**

This hole is used to mount the camera onto a mounting bracket.

⑤ **Focus Fixing Screw**

⑥ **Down Button (⏴)**

This button is used to move the cursor downward. It is also used to select items in the CAM SET UP menu.

⑦ **Right Button (⏵)**

This button is used to move the cursor to the right. It also selects the mode and can be used to adjust some levels.

⑧ **Left Button (⏴)**

This button is used to move the cursor to the left. It also selects the mode and can be used to adjust some levels.

⑨ **Up Button (⏵)**

This button is used to move the cursor upward. It is also used to select items in the CAM SET UP menu.

⑩ **Set Button (⏹)**

This button is used to activate an item selected in the CAM SET UP menu.

⑪, ⑬ **Selector (NC)**

This selector is not used on this camera.

⑫ **Detail Level Selector (SOFT-SHARP)**

This selector is used to select the detail / aperture level as follows.

SOFT: When a quad system is connected to this camera, select this position.

SHARP: Select this position usually.

⑭ **Power indicator**

This indicator lights up when the power of this camera is on.

⑮ **Monitor Output Connector (MONITOR OUT)**

This connector is used to connect with the video input connector of the monitor.

⑯ **Video Output Connector (VIDEO OUT)**

This connector is used to connect a coaxial cable to the camera input connector of the specified monitor or camera drive unit, to receive DC power and vertical drive pulse, and supply the video output of the camera.

⑰ **Rear Cover**

The rear cover can be removed, if you require.

CONNECTIONS

Caution: Keep the POWER switch of the specified monitor, Camera Extension Unit and Camera Drive Unit in OFF position while making connections. If the power of these units is ON during connections, the camera does not function due to the built-in protection circuit which protects it against wrong connections.

Basic System

Connect the coaxial cables between the camera and CAMERA IN connector of the specified monitor or Camera Drive Unit. The approximate maximum cable length is as follows:

Coaxial Cable Type	Maximum Cable Length	DC R/1000 ft. of Inner Conductor
RG-59/U	200 m (660 ft)	Less than 30 Ω
RG-6/U	500 m (1 650 ft)	Less than 12 Ω

The maximum DC resistance between the camera and these unit is 20 Ω .

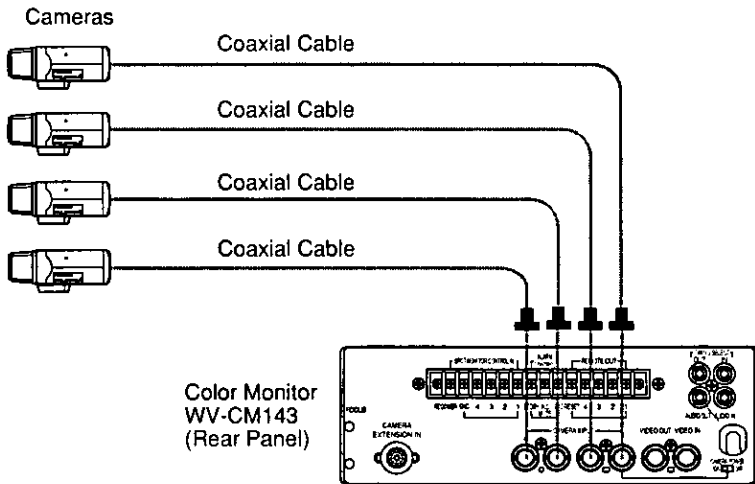

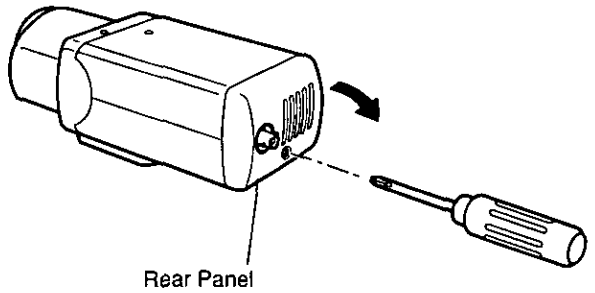

Mounting the Lens

Caution:

Before you mount the lens, loosen the screw on the side of the camera, and rotate this ring clockwise until it stops. If the ring is not at the end, the inner glass or CCD image sensor may be damaged.

1. Mount the lens by turning it clockwise on the lens mount of the camera.
2. Connect the lens cable to the auto iris lens connector on the side of the camera.

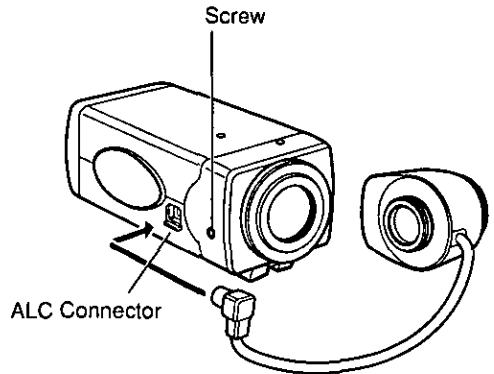

Caution for Mounting the Lens

The lens mount should be a CS-mount (1"-32UN) and the lens weight should be less than 450 g (0.99 lbs). If the lens is heavier, both the lens and camera should be secured by using the supporter.

The protrusion at the rear of the lens should be as shown below:

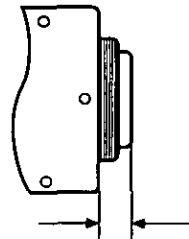

CS-mount: Less than 8 mm (5/16")

FOCUS OR FLANGE-BACK ADJUSTMENT

The following adjustment should be made by qualified service personnel or system installers.

1. Loosen the screw on the side of the camera.
2. Turn the flange-back adjusting ring to the desired position.

Caution: Do not rotate the ring counterclockwise by force after it stops. If the ring is rotated by force, the inner lens or CCD image sensor may be damaged.

3. Tighten the screw on the side of the camera.

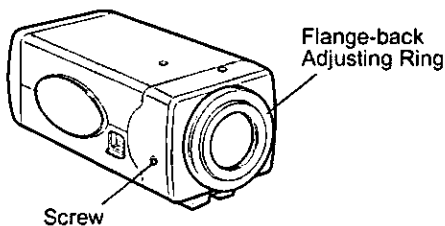

Cautions:

- Tightening the screw by force will cause damage to the screw or deviation of focus.
- To use the C-mount lens, the Lens Mount Converter (C-mount adapter) WV-AD20 should be used with the camera.

INSTALLATION OF CAMERA

The mounting bracket can be fixed either on the top or bottom cover of the camera.

• Mounting from the top

Remove the mount adapter from the bottom of the camera by removing the two fixing screws. The mounting hole is a standard photographic pan-head screw size (1/4" - 20). Attach the mount adapter to the top as shown in the diagram, then mount the camera on the mounting bracket.

Make sure that the two original fixing screws are used when mounting the mount adapter as longer length screws may damage inner components.

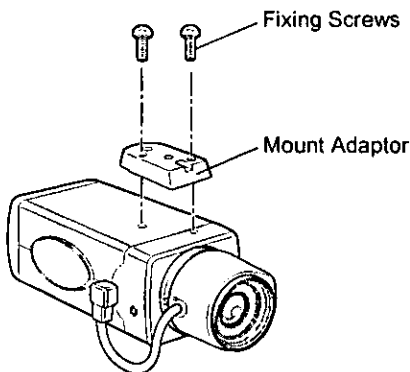

INSTALLATION PROCEDURE

Following explanation for installing the camera mounting bracket is for the installation on the wall (A and B), but also applies equally to the installation on the ceiling, a shelf and stand.

1. Install the camera mounting bracket on the wall with 2 screws.

Note: The coaxial cable can be passed through the center hole of the camera mounting bracket.

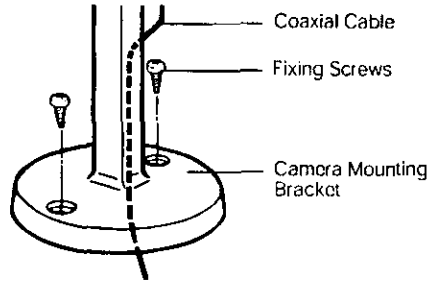

2. Insert the camera fixing screw into the camera mounting hole and tighten the screw firmly.

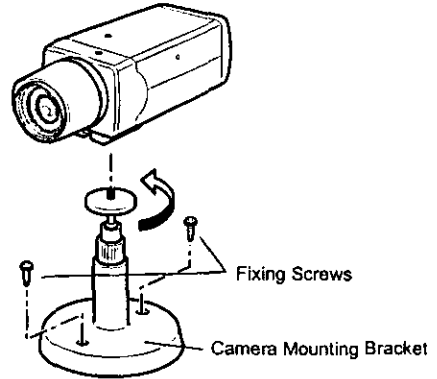

3. Connect the camera and monitor with the coaxial cable and turn on the power switch of the monitor.
4. While viewing the monitor picture, loosen the angular control screw slightly. Adjust the camera's angle to the desired position, and then tighten the screw firmly.

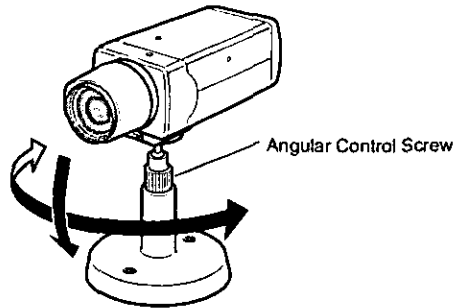

DIMENSIONS OF MOUNTING BRACKET

Caution on installation

Use wood screws with the camera mounting bracket that are suitable for installation into a wood base of appropriate dimensions and strength. For installation in a material other than wood, refer servicing to qualified service personnel.

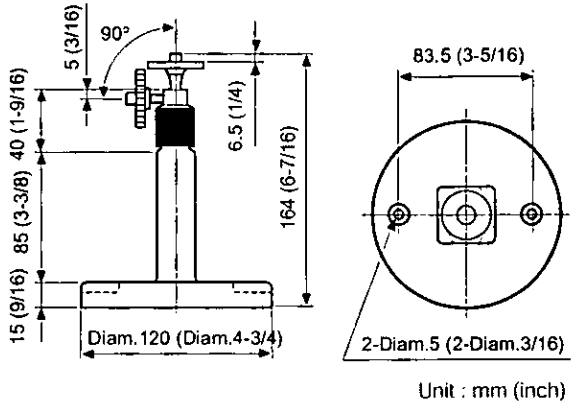

SETUP

1. CAMERA SETUP MENU

This camera utilizes a user setup menu that is displayed on-screen.

• Opening the Setup Menu

Press and hold down  for 2 seconds or more.

The CAM SET UP menu appears on the monitor as shown at right.

Check the current settings on the menu.

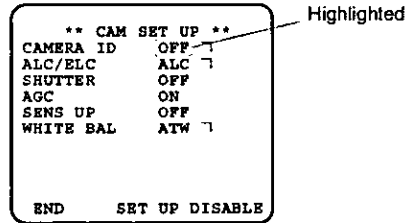

Refer to the sections below for a detailed description of menu items. If you decide not to make any changes after checking the current settings, move the cursor to END at the start of the bottom line, and press  to close the CAM SET UP menu and return to normal camera picture mode.





Note: If no button is pressed for 5 minutes while the CAM SET UP menu or any other menu is opened, the menu is automatically closed and the mode returns to the normal camera picture.

2. SETUP OPERATION

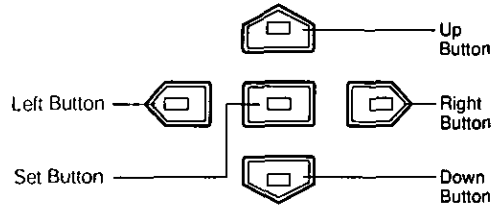
This camera utilizes a user setup menu (CAM SET UP) that is displayed on the monitor.

To set items on the CAM SET UP menu, use the following buttons on the side panel.





- Up Button (): Moves the cursor upwards. Use this button to select an item or adjust the parameters.
- Down Button (): Moves the cursor downwards. Use this button to select an item or adjust the parameters.
- Right Button (): Moves the cursor to the right. Use this button to select or adjust the parameters of the selected item. The parameter changes each time this button is pressed.
- Left Button (): Moves the cursor to the left. Use this button to select or adjust the parameters of the selected item. The parameter changes each time this button is pressed.
- Set Button (): Executes selections and displays a submenu for an item with \uparrow mark. END: Close Setup menu. RET: Return to the previous menu.

To return to the CAM SET UP menu

Move the cursor to RET and press  . The CAM SET UP menu appears.

• All Reset Operation

All Reset allows you to reset all setup menu items to the factory default settings if you are unsure about the correct settings. Proceed as follows:





- (1) Make sure that the CAM SET UP menu is not displayed (a camera picture is displayed).
- (2) While pressing both  and  , press  for a few seconds. The message ALL RESET momentarily appears on the monitor.

This resets all adjustments and parameters to the factory default settings.

• Editing the CAM SET UP Menu

Important Notice:

When the SET UP DISABLE appears in the bottom line of the CAM SET UP menu, you cannot change the currently active settings. This is to prevent accidental changing of the settings.

To edit the CAM SET UP menu (change settings), press  and  or  and  to move the cursor to SET UP DISABLE in the bottom line.

Press  . SET UP DISABLE changes to SET UP ENABLE. Move the cursor to END, then to the item(s) you want to change.

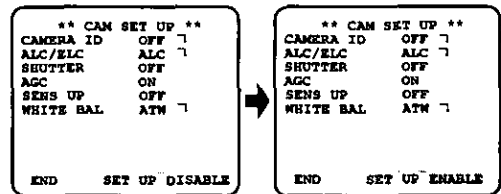

• Editing the SPECIAL Menu

To edit the SPECIAL menu (change settings), proceed as for editing the CAM SET UP menu above. Move the cursor to END after the SET UP ENABLE appears. Then press and simultaneously for 2 seconds or more.

The SPECIAL menu appears on the monitor. Select the item to be changed and change the setting as described for the CAM SET UP menu.

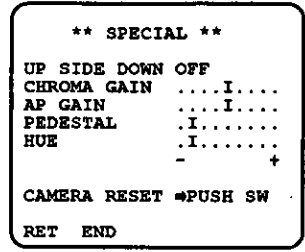

Important Notice:

When the cursor is moved to END and the CAM SET UP menu closed after changing the parameters, the new values are saved in the EEPROM (Electric Erasable and Programmable Read Only Memory). These values remain valid until new values are saved, even if the power of the camera is off.

SETTING PROCEDURES

1. Camera Identification (CAMERA ID) Setting

You can use the camera identification (CAMERA ID) to assign a name to the camera. The camera ID consists of up to 16 alphanumeric characters. The camera ID display can be selected on or off on the monitor screen.

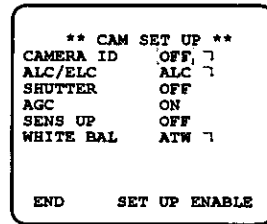

To edit the CAMERA ID



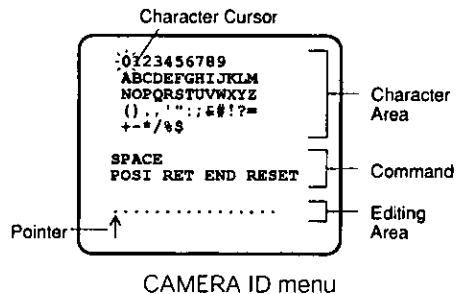

1. Move the cursor to the CAMERA ID parameter.
2. Press . The CAMERA ID menu appears. The cursor on the letter "0" is highlighted.
3. Move the cursor to the character you want to edit or change by pressing / / / .
4. After selecting the character, press . The selected character appears in the editing area. (The pointer in the editing area moves to the right automatically at this moment.)
5. Repeat the steps above until all characters are edited.



To enter a blank space in the CAMERA ID

Move the cursor to SPACE and press .

To replace a specific character in the CAMERA ID

1. Move the cursor to the editing area by pressing  or .
2. Move the pointer to the character to be replaced by pressing  or . Then move the cursor to the character area and select a new character.
3. Press  to determine the CAMERA ID.





To erase all characters in the editing area

Move the cursor to RESET and press . All characters in the editing area disappear.

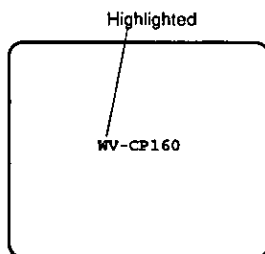



To determine the display position of the CAMERA ID

1. Move the cursor to POSI, and press .
The display shown below appears and the CAMERA ID is highlighted.



2. Move the CAMERA ID to the desired position by pressing  /  /  / .
3. Press  to fix the position of the CAMERA ID. The mode returns to the previous CAMERA ID menu.

Notes:

- The CAMERA ID stops at the edges of the monitor screen.
- The CAMERA ID moves faster if any of  /  /  /  is kept pressed for a second or more.

2. Light Control Setting (ALC/ELC)

You can select the light control mode according to the lens type.

ALC: If you use the auto iris lens, select this parameter.

ELC: If you use a fixed or manual iris lens, select this parameter.

1. Move the cursor to the ALC/ELC parameter.
2. Select ALC or ELC.

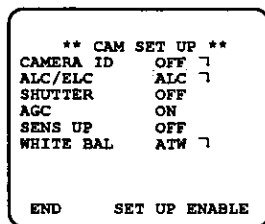

2-1. ALC Mode with SUPER-D2 ON

Super Dynamic 2 Function (SUPER-D2)

The important object in a scene is usually placed in the center of the monitor's screen. In SUPER-D2 mode, the dynamic range is 64 times greater than a conventional camera. This allows you to see all the details on the monitor, even under difficult lighting condition. You can use the SUPER-D2 function if you select ALC.

1. After selecting ALC, press **[MENU]** to open the ALC CONT menu.
2. Move the cursor to the SUPER-D2 parameter and select ON

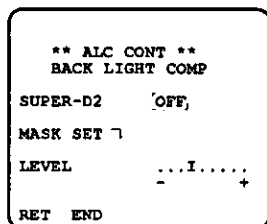

3. If you want to adjust the video output level, move the cursor to the "I" position. Adjust to the desired level by pressing **[LEFT]** or **[RIGHT]**.

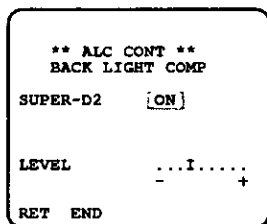

2-2. ALC Mode with SUPER-D2 OFF and ELC Mode

Note: If ELC is selected, set MASK SET according to this procedure.

1. Move the cursor to the SUPER-D2 parameter and select OFF. (When you select ELC, SUPER-D2 is not available.) The item MASK SET appears on the menu.
2. Move the cursor to MASK SET and press **[MENU]**. 48 mask areas appear on the monitor screen. The cursor is blinking in the upper left corner of the screen.

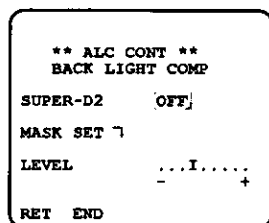

3. Move the cursor to the area where backlight is bright and press **[A]** to mask that area. The mask turns to white. (When the cursor is moved on an area that has already been masked, the mask and cursor start blinking.)
4. Repeat step 3 to mask the desired area. To cancel masking, move the cursor to that area and press **[A]**.
5. After masking is completed, press **[A]** for 2 seconds or more. The ALC CONT menu appears.
6. If you want to change the video output level (picture contrast), move the "I" cursor for LEVEL and adjust the level.

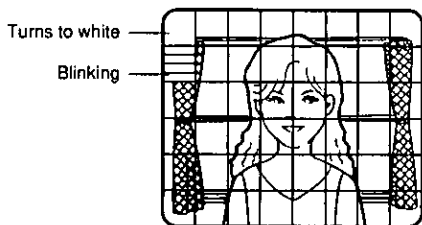
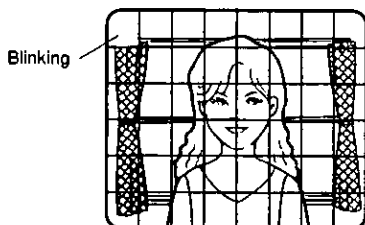
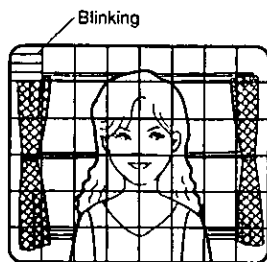

Note: If ON is selected for the SUPER-D2 parameter, a shadow (black line) may appear at the boundary between the bright and the dim scene. This is a natural phenomenon and does not indicate trouble.

3. Shutter Speed (SHUTTER)

Move the cursor to the SHUTTER parameter and select the electronic shutter speed. The preset values for SHUTTER change by pressing **[A]** or **[B]** as shown right.

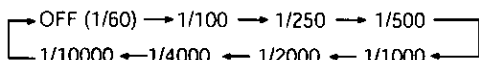

Note: When ELC is selected for ALC/ELC or ON is selected for SUPER-D2, this item is not available.

4. Gain Control Setting (AGC ON/OFF)

You can set the gain (brightness level portion of an image) to automatic level adjustment (ON) or fixed level (OFF).

Move the cursor to the AGC parameter and select automatic level adjustment (ON) or fixed level (OFF).

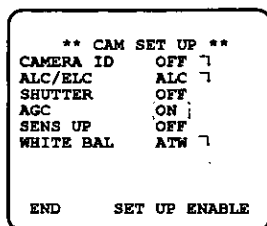

Note: If ON is selected for the AGC parameter, the noise reduction function is automatically activated under low light conditions to reduce noise. In pictures containing a moving object, this may result in an afterimage.

5. Electronic Sensitivity Enhancement (SENS UP)



There are two modes for SENS UP.

AUTO: If you select X10 AUTO, for example, the sensitivity is raised automatically to X10 max. When AUTO is selected, AGC is automatically set to ON.

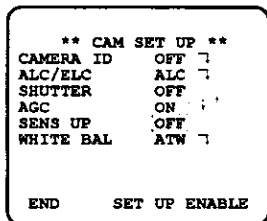
FIX: If you select X32 FIX, for example, the sensitivity is raised to just X32.



Move the cursor to the SENS UP parameter and select the parameter for electronic sensitivity enhancement.

The preset values for SENS UP (electronic sensitivity enhancement) change by pressing  or  as shown at right:

- When OFF is selected for SUPER-D2 on the CAM SET UP menu.

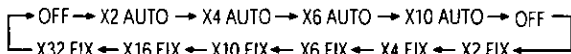

- When ON is selected for SUPER-D2 on the CAM SET UP menu.

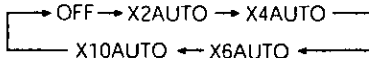

Notes:

- When ON is selected for SUPER-D2 in the ALC CONT menu, FIX is not available for this item.
- When you select AUTO for SENS UP and ON for SUPER-D2, the SENS UP function has priority so that the SUPER-D2 function is not activated automatically.
- While the SENS UP function is selected, noise, spots or a whitish phenomenon may appear in the picture when the sensitivity of the camera is increased. This is a normal phenomenon.

6. White Balance Setting (WHITE BAL)

6-1. Auto-Tracing White Balance Mode (ATW)

You can select one of two modes for white balance adjustment as follows:

- **ATW (Auto Tracing White Balance)**

In this mode, the color temperature is monitored continuously and thereby white balance is set automatically. The color temperature range for the proper white balance is approximately 2 600 - 6 000K. Proper white balance may not be obtained under the following conditions:

1. The color temperature is out of the 2 600 - 6 000K range.
2. When the scene contains mostly high color temperature objects, such as a blue sky or sunset.
3. When the scene is dim.

In these cases, select the AWC mode.

Move the cursor to the WHITE BAL parameter and select ATW. The white balance of the camera is automatically set.

```
      ** CAM SET UP **
CAMERA ID   OFF  7
ALC/ELC     ALC  7
SHUTTER     OFF
AGC         ON
SENS UP     OFF
WHITE BAL   [ATW  7

      END      SET UP ENABLE
```

- **Automatic White Balance Control Mode (AWC)**

In this mode, accurate white balance is obtained within a color temperature range of approximately 2 300-10 000K.

1. Move the cursor to the WHITE BAL parameter and select AWC → PUSH SW.

```
      ** CAM SET UP **
CAMERA ID   OFF  7
ALC/ELC     ALC  7
SHUTTER     OFF
AGC         ON
SENS UP     OFF
WHITE BAL   [AWC-PUSH SW

      END      SET UP ENABLE
```

2. Press  to start the white balance setup. The PUSH SW is highlighted to indicate that the white balance is being set.

```
      ** CAM SET UP **
CAMERA ID   OFF  7
ALC/ELC     ALC  7
SHUTTER     OFF
AGC         ON
SENS UP     OFF
WHITE BAL   [AWC-PUSH SW

      END      SET UP ENABLE
```

3. When the white balance setting is completed, the PUSH SW returns to normal display.

Note: In case that the white balance is not set, the PUSH SW is being highlighted.

4. When you want to adjust the white balance manually, press **⏪** to select AWC and press **⏩**. The AWC menu appears on the monitor. (When ATW is selected, pressing **⏩** displays the ATW menu.)

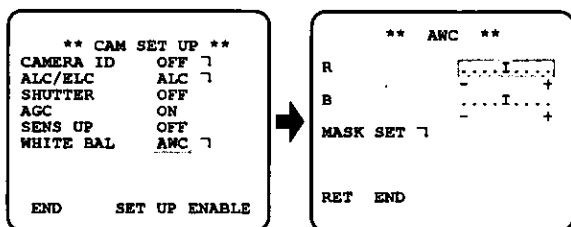

Fine Adjustment for AWC (ATW) Manually

You can add the detailed setting for white balance setting manually.

1. To set MASK SET, proceed as described in steps 2 to 4 of "ALC mode with SUPER-D2 OFF and ELC mode".
2. Move the cursor to R.
3. Press **⏪** or **⏩** to obtain the optimum amount of red gain.
4. Move the cursor to B.
5. Press **⏪** or **⏩** to obtain the optimum amount of blue gain.

Note: When you need to set MASK SET, re-adjust to obtain the optimum amount of red and blue gain.

7. Special Menu

This menu lets you adjust and set up the video signal of the camera to meet your requirements.

Move the cursor to END on the bottom line of the CAM SET UP menu and press **⏪** and **⏩** simultaneously (holding down **⏪** and press **⏩**) for 2 seconds or more. The SPECIAL menu appears on the monitor as shown at right.

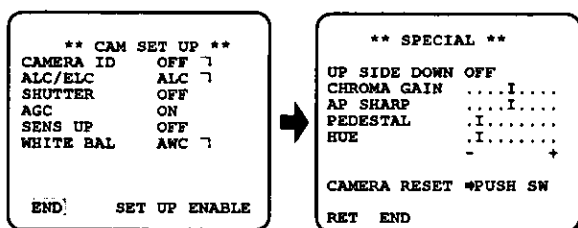

7-1. Camera Picture Upside Down Positioning (UP SIDE DOWN)

1. Move the cursor to the UP SIDE DOWN parameter.
2. Select ON when you desire to turn the picture upside down.

7-2. Chroma Level Setting (CHROMA GAIN)

1. Move the cursor to the CHROMA GAIN parameter.
2. While observing the vectorscope or color video monitor, move the "I" cursor to adjust the chroma level.

7-3. Aperture Sharpness (Softness) Setting (AP SHARP/AP SOFT)

Note: This item changes according to the position of the detail level selector (SOFT/SHARHP) on the side of the camera.

1. Move the cursor to the AP SHARP (AP SOFT) parameter.
2. While observing the color video monitor, move the "I" cursor to adjust the aperture gain level.



7-4. Pedestal Level Setting (PEDESTAL)

1. Move the cursor to the PEDESTAL parameter.
2. While observing the waveform monitor or color video monitor, move the "I" cursor to adjust the pedestal level (black level).

7-5. Chroma Phase (Hue) Setting (HUE)

1. Move the cursor to the HUE parameter.
2. While observing the vectorscope or color video monitor, move the "I" cursor to adjust the hue (chroma phase) level.

To reset to the factory settings (CAMERA RESET)

1. Move the cursor to the CAMERA RESET parameter. PUSH SW is highlighted.
2. While holding down  and , press  for 2 seconds or more. The camera is reset to the factory settings.

To close the SPECIAL menu and return to the CAM SET UP menu

Move the cursor to RET and press .

To close the SPECIAL menu and return to the camera picture

Move the cursor to END and press .

PREVENTION OF BLOOMING AND SMEAR

When the camera is aimed at a bright light, such as a spotlight, or a surface that reflects bright light, smear or blooming may appear. Therefore, the camera should be operated carefully in the vicinity of extremely bright objects to avoid smear or blooming.

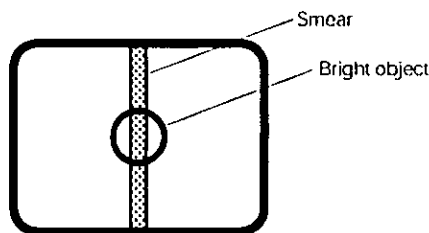

SPECIFICATIONS

Pick-up Device:	768 (H) x 494 (V) pixels, Interline Transfer CCD ¹⁾
Scanning Area:	4.8 (H) x 3.6 (V) mm (Equivalent to scanning area of 1/3" pick-up tube)
Scanning:	525 lines/60 fields/30 frames
Horizontal:	15.734 kHz
Vertical:	59.94 Hz
Synchronization:	Multiplexed Vertical Drive (VD2) by use of specified camera drive unit.
Video Output:	1.0 V[p-p] NTSC composite 75 Ω /through camera drive unit
Horizontal Resolution:	480 lines
Signal-to-Noise Ratio:	50 dB (AGC OFF, weight ON)
Dynamic Range:	46 dB
Minimum Illumination:	0.4 lx (0.04 footcandle) at F0.75 [Equivalent to 0.8 lx (0.08 footcandle) at F1.4]
Gain Control:	AGC ON or OFF (SET UP MENU) selectable
White Balance:	ATW or AWC (SET UP MENU) selectable
Aperture:	Set Variable (SET UP MENU) Sharp-Soft selectable by detail level selector
Electronic Light Control:	ALC/ELC
Super Dynamic II :	ON or OFF (SET UP MENU) selectable
Electronic Shutter Speed:	OFF, 1/100 1/250, 1/500, 1/1 000 1/2 000, 1/4 000, 1/10 000 s selectable
Lens Mount:	CS-mount
ALC Lens:	DC drive
Ambient Operating Temperature:	- 10°C - +50°C (14°F - 122°F)
Ambient Operating Humidity:	Less than 90 %
Power Source:	From the specified monitor or camera drive unit
Power Consumption:	310 mA
Dimensions (without lens):	68 (W) x 65 (H) x 126 (D) mm [2-11/16" (W) x 2-9/16" (H) x 4-15/16" (D)]
Weights (without lens):	0.375 kg (0.8 lbs.)

Weights and dimensions indicated are approximate.
Specifications are subject to change without notice.

STANDARD ACCESSORIES

Body Cap1 pc.
Camera Mounting Bracket1 pc.

OPTIONAL ACCESSORIES

Lenses : WV-LA2R8C3B, WV-LA4R5C3B, WV-LA9C3B, WV-LA210C3, WV-LA408C3,
WV-LA908C3, WV-LZ61/10, WV-LZ61/15, WV-LZ60/2, WV-LZ62/8

Panasonic Security and Digital Imaging Company

A Division of Matsushita Electric Corporation of America

Executive Office: One Panasonic Way 3E-7, Secaucus, New Jersey 07094

Regional Offices:

Northeast: One Panasonic Way, Secaucus, NJ 07094 (201) 348-7303

Southern: 1225 Northbrook Parkway, Suite 1-160, Suwanee, GA 30024 (770) 338-6838

Midwest: 1707 North Randall Road, Elgin, IL 60123 (847) 468-5211

Western: 6550 Katella Ave., Cypress, CA 90630 (714) 373-7840

Panasonic Canada Inc.

5770 Ambler Drive, Mississauga,
Ontario, L4W 2T3 Canada (905)624-5010

Panasonic Sales Company

Division of Matsushita Electric of Puerto Rico Inc.

Ave. 65 de Infanteria. Km. 9.5
San Gabriel Industrial Park, Carolina,
Puerto Rico 00985 (809)750-4300